

**Makita**<sup>®</sup>



# POWER EQUIPMENT ACCESSORIES



Sep17



**T-01753A**

**10MM LH COMFORT TRIM BUMP & FEED**



**INCLUDES**

- ▶ .095 cutting line
- ▶ M10 X 1.25 LH arbor

**FITS MODELS**

XRU09	MS-246.4C
EM2650LH	MS-256.4C
EM2650UH	MS-335.4C
EM2652LHN	CS-246.4C
MS-245.4U	
MS-245.4C	

**LINE CAPACITY**

20 ft. of .080
18 ft. of .095
16 ft. of .105
13 ft. of .110



**T-02917**

**8MM LH COMFORT TRIM BUMP & FEED**



**INCLUDES**

- ▶ .095 cutting line
- ▶ M8 X 1.25 LH arbor

**FITS MODELS**

XRU04Z	
MS-27C	

**LINE CAPACITY**

20 ft. of .080
18 ft. of .095
16 ft. of .105
13 ft. of .110



**T-03187**

**8MM RH COMFORT TRIM BUMP & FEED**



**INCLUDES**

- ▶ .095 cutting line
- ▶ M8 X 1.25 RH arbor

**FITS MODELS**

XRU08Z	
XRU07Z	
LT-27C	

**LINE CAPACITY**

20 ft. of .080
18 ft. of .095
16 ft. of .105
13 ft. of .110



**713300-C**

**MANUAL FEED TRIMMER HEAD**



**INCLUDES**

- ▶ 713300-C manual feed head
- ▶ .095 cutting line
- ▶ M10 X 1.25 LH shaft bolt

**FITS MODELS**

XRU09	MS-245.4C
EM2650LH	MS-246.4C
EM2650UH	MS-256.4C
EM2652LHN	MS-335.4C
MS-245.4U	CS-246.4C

**LINE CAPACITY**

30 ft. of .080
20 ft. of .095
20 ft. of .105
10 ft. of .130

**713301-C****BUMP & FEED TRIMMER HEAD**

INCLUDES
<ul style="list-style-type: none"> <li>▶ 713301-C bump &amp; feed head</li> <li>▶ .095 cutting line</li> <li>▶ M10 X 1.25 LH shaft bolt</li> </ul>

FITS MODELS
XRU09 MS-245.4C
EM2650LH MS-246.4C
EM2650UH MS-256.4C
EM2652LHN MS-335.4C
MS-245.4U CS-246.4C

LINE CAPACITY
30 ft. of .080
20 ft. of .095
20 ft. of .105
10 ft. of .130

**TRIMMER  
BRUSHCUTTER****B-05119****HIGH CAPACITY BUMP & FEED**

INCLUDES
<ul style="list-style-type: none"> <li>▶ .095 cutting line</li> <li>▶ M10 X 1.25 LH arbor</li> </ul>

FITS MODELS
EM2650LH MS-256.4C
EM2650UH MS-335.4C
EM2652LHN CS-246.4C
MS-245.4U
MS-245.4C
MS-246.4C

LINE CAPACITY
30 ft. of .080
20 ft. of .095
20 ft. of .105
10 ft. of .130

**B-60121****BUMP & AUTO FEED TRIMMER HEAD**

INCLUDES
<ul style="list-style-type: none"> <li>▶ .095 trimmer line</li> <li>▶ A-Nut M8 X 1.25 RH</li> <li>▶ B-Nut 3/8" X 24 RH</li> <li>▶ Special Wrench</li> </ul>

FITS MODELS
XRU07Z
MS-27 C

LINE CAPACITY

**B-60109****BUMP & AUTO FEED**

INCLUDES
<ul style="list-style-type: none"> <li>▶ .095 trimmer line</li> <li>▶ Nut M10 X P1.25</li> <li>▶ Nut M8 X P 1.25</li> <li>▶ Stud M8 X P1.25</li> <li>▶ Stud M7 X P1.0</li> <li>▶ Special Wrench</li> </ul>

FITS MODELS
XRU09 MS-256.4C
EM2650LH MS-335.4C
EM2650UH CS-246.4C
EM2652LHN XRU04Z
MS-245.4U MS-27C
MS-245.4C
MS-246.4C

LINE CAPACITY
17 ft. of .080
12 ft. of .095
10 ft. of .105
9 ft. of .110



### BUMP & FEED TRIMMER HEAD, DOLMAR

126048-5



TRIMMER  
BRUSHCUTTER

		<b>INCLUDES</b>	<b>FITS MODELS</b>	<b>LINE CAPACITY</b>
		<ul style="list-style-type: none"> <li>▶ .095 cutting line</li> <li>▶ M8 X 1.25 RH</li> </ul>	LT-210 LT-27C	20 ft. of .080 16 ft. of .095 14 ft. of .105 13 ft. of .110



197297-1

### BUMP & FEED TRIMMER HEAD



		<b>INCLUDES</b>	<b>FITS MODELS</b>	<b>LINE CAPACITY</b>
		<ul style="list-style-type: none"> <li>▶ .080 trimmer line</li> <li>▶ Nut M10 X P1.25 RH</li> </ul>	XRU07	17 ft. of .080 12 ft. of .095 10 ft. of .105 9 ft. of .110





B-02951

### FIXED LINE TRIMMER HEAD

B-02951



		<b>INCLUDES</b>	<b>FITS MODELS</b>	<b>LINE CAPACITY</b>
		<ul style="list-style-type: none"> <li>▶ B-60115 manual trimmer head</li> <li>▶ .130 line</li> </ul> <p><b>NOTE:</b> B-60115 requires arbor nut with washer for installation M10 x 1.25 LH Nut Part # 264025-0 or M8 x 1.25 LH Nut Part # 264018-7</p>	XRU09      MS-256.4C EM2650LH    MS-335.4C EM2650UH    CS-246.4C EM2652LHN   XRU04Z MS-245.4U    MS-27C MS-245.4C MS-246.4C	5 ft. of .105 5 ft. of .110 4 ft. of .130



**B-14118**

**9" STAR BLADE, 4 TOOTH**

**362-224-140**



**TRIMMER  
BRUSHCUTTER**



INCLUDES	
▶ 9" star blade, 4 tooth	

FITS MODELS	
EM2650LH*	MS-256.4C*
EM2650UH	MS-335.4C
EM2652LHN*	MS-27C
MS-245.4U	
MS-245.4C	
MS-246.4C	



▶ \* Requires blade kit PN 196500-7



**196500-7**

**BRUSH CUTTER CONVERSION KIT**



INCLUDES	
▶ Harness	▶ Cup
▶ Protector	▶ M10-17 Nut
▶ Barrier Bar	▶ Universal
▶ Clamp	▶ Wrench
▶ Washer	

FITS MODELS	
EM2650LH	
EM2652LHN	
MS-245.4C	
MS-246.4C	
MS-256.4C	
MS-335.4C	



**122906-3**

**BRUSHCUTTER HARNESS**

**988-048-324**



INCLUDES	
▶ Harness	

FITS MODELS	
EM2650LH	MS-256.4C
EM2650UH	MS-335.4C
EM2652LHN	CS-246.4C
MS-245.4U	XRU04Z
MS-245.4C	MS-27C
MS-246.4C	XRU07Z



**197680-2**

**TRIMMER SERVICE KIT**



INCLUDES	
▶ Spark Plug	
▶ Fuel Filter	
▶ Air Filter	

FITS MODELS	
EM2650LH	EE2650H
EM2650UH	EN5950SH
EM2652LHN	EN4950H
MS-246.4C	EN7350SH
MS-256.4C	EN4951SH
CS-246.4C	EN5550SH
EY2650H25H	

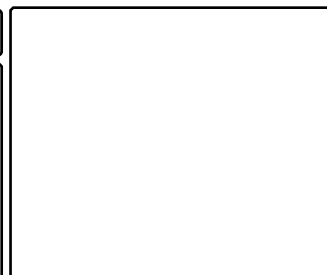



**135683-8**

**ARTICULATING TRIMMER ATTACHMENT**



INCLUDES
▶ blade cover

FITS MODELS	
EM2650LH	EN4950SH
EM2652LHN	EN4951SH
MS-245.4C	EN5950SH
MS-246.4C	EN7350SH
MS-256.4C	MH-246.4DS
MS-27C	



**A-89523**

**ARTICULATING TRIMMER ATTACHMENT**



INCLUDES
▶ blade cover

FITS MODELS	
EM2650LH	EN4950SH
EM2652LHN	EN4951SH
MS-245.4C	EN5950SH
MS-246.4C	EN7350SH
MS-256.4C	MH-246.4DS
MS-27C	



**135544-2**

**DOUBLE-SIDED TRIMMER ATTACHMENT**

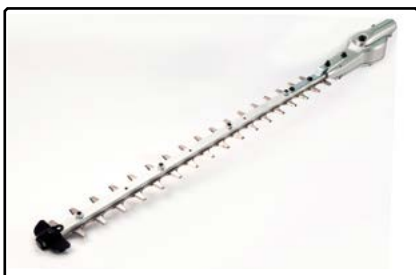

INCLUDES
▶ blade covers

FITS MODELS	
EM2650LH	EN4950SH
EM2652LHN	EN4951SH
MS-245.4C	EN5950SH
MS-246.4C	EN7350SH
MS-256.4C	MH-246.4DS
MS-27C	



**135545-0**

**SINGLE-SIDED TRIMMER ATTACHMENT**



INCLUDES
▶ blade covers

FITS MODELS	
EM2650LH	EN4950SH
EM2652LHN	EN4951SH
MS-245.4C	EN5950SH
MS-246.4C	EN7350SH
MS-256.4C	MH-246.4DS
MS-27C	



**196315-2**

**POLE SAW ATTACHMENT**



<b>LENGTH (in.)</b>	10
<b>PITCH (in.)</b>	3/8
<b>GAUGE (in.)</b>	.050
<b>DRIVE LINKS</b>	39
<b>CHAIN TYPE</b>	91V, Low Kickback
<b>BAR MOUNT</b>	Oregon Ref #A318

INCLUDES
▶ 10 in. bar
▶ 10 in. saw chain
▶ chain protector

FITS MODELS	
EM2650LH	EN4950SH
EM2652LHN	EN4951SH
MS-245.4C	EN5950SH
MS-246.4C	EN7350SH
MS-256.4C	
MS-27C	



195282-8

VACUUM KIT



INCLUDES

- ▶ Dust bag
- ▶ Elbow
- ▶ Pipe

FITS MODELS

BHX2500CA  
PB-251.4



451753-8

FLAT END NOZZLE

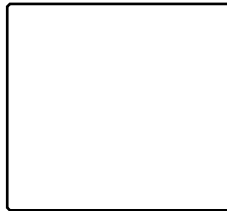

INCLUDES

- ▶ Nozzle

FITS MODELS

BHX2500CA  
PB-251.4



667-95002-01

SHORT END NOZZLE



INCLUDES

- ▶ Nozzle

FITS MODELS

BBX7600CA  
BBX7600N  
PB-7602.4  
PB-7601.4



454896-5

END NOZZLE 90-60

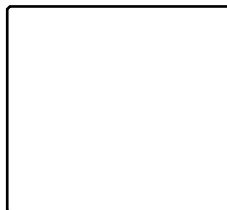

INCLUDES

- ▶ Nozzle

FITS MODELS

EB7650WH  
EB7650TH



454916-5

FLAT NOZZLE 90

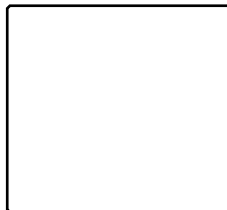

INCLUDES

- ▶ Nozzle

FITS MODELS

EB7650WH  
EB7650TH



455128-3

END NOZZLE 90-70



INCLUDES

- ▶ Nozzle

FITS MODELS

EB7650WH  
EB7650TH

BLOWER



197888-8

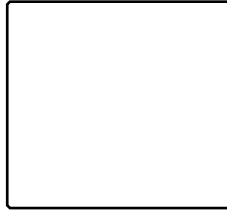

INCLUDES
▶ Nozzle

FITS MODELS
XBU02



197889-6

FLAT NOZZLE

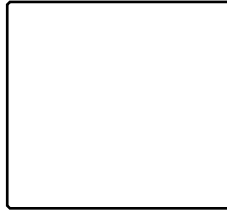

INCLUDES
▶ Nozzle

FITS MODELS
XBU02

BLOWER





195826-4

10W-30 ENGINE OIL



<b>SIZE</b>	80 cc bottle
<b>FOR USE WITH</b>	All Makita 4-stroke Models



195826-4-48

10W-30 ENGINE OIL 48 PACK



<b>SIZE</b>	80 cc bottles, 48 pack
<b>FOR USE WITH</b>	All Makita 4-stroke Models

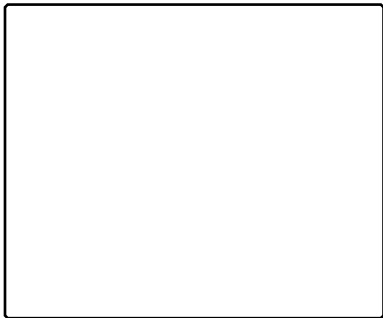

T-02484

10W-30 ENGINE OIL



<b>SIZE</b>	200 cc bottle
<b>FOR USE WITH</b>	All Makita 4-stroke Models

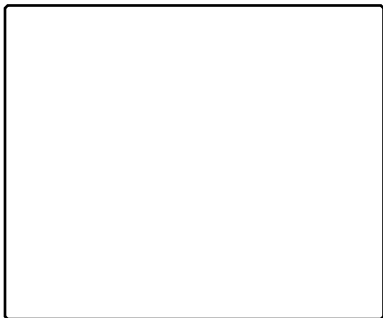

T-02490

10W-30 ENGINE OIL, 12 PACK



<b>SIZE</b>	200 cc bottles, 12 pack
<b>FOR USE WITH</b>	All Makita 4-stroke Models



ENGINE OIL  
FUEL MIX



**T-00745**

**1 GALLON MIX, 50:1 2 CYCLE FUEL MIX**



<b>SIZE</b>	2.6 oz bottle
<b>FOR USE WITH</b>	All Makita 2 Cycle Engines



**T-00745-48**

**1 GALLON MIX, 50:1 2 CYCLE FUEL MIX (48)**



<b>SIZE</b>	2.6 oz bottle, 48 pack
<b>FOR USE WITH</b>	All Makita 2 Cycle Engines

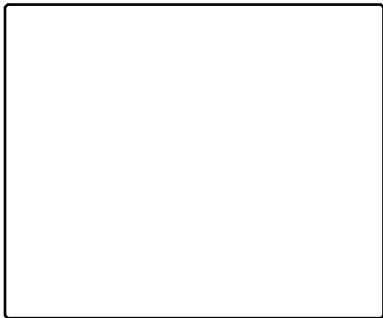

**T-00739**

**2.5 GALLON MIX, 50:1 2 CYCLE FUEL MIX**



<b>SIZE</b>	6.4 oz bottle
<b>FOR USE WITH</b>	All Makita 2 Cycle Engines

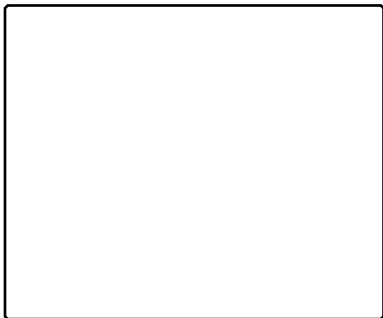

**T-00739-48**

**2.5 GALLON MIX, 50:1 2 CYCLE FUEL MIX**



<b>SIZE</b>	6.4 oz bottle, 48 pack
<b>FOR USE WITH</b>	All Makita 2 Cycle Engines



**ENGINE OIL  
FUEL MIX**



957-173-400

HEAVY DUTY FILTER KIT



<b>SIZE</b>	N/A		
<b>FOR USE WITH</b>	DCS640120	PS-7310	
	DCS642120	PS-7910	
	PS-6400		



B-70777

CHAIN SAW PLASTIC TOOL CASE



<b>FOR USE WITH</b>	EA3201S	EA5000P	PS-421	PS-6100
	EA3601F	EA6100P	PS-510	EA5600F
	EA4300F	PS-32C	PS-5105	
	DCS5121	PS-35C	PS-5105H	



181119-A

1 QT. BAR CHAIN OIL



<b>SIZE</b>	1 qt.
<b>FOR USE WITH</b>	All chain saws



181116-A

1 GAL. BAR CHAIN OIL



<b>SIZE</b>	1 gal.
<b>FOR USE WITH</b>	All chain saws



1 GAL. BAR CHAIN OIL (4)

997-600-005

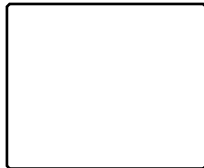

<b>SIZE</b>	1 gal. bottles, 4 pack
<b>FOR USE WITH</b>	All chain saws



T-03159

1 QT. WINTER BAR CHAIN OIL



<b>SIZE</b>	1 qt.
<b>FOR USE WITH</b>	All chain saws

CHAIN SAW



T-03159-4

1 QT. WINTER BAR CHAIN OIL (4 PK)



**SIZE** 1 qt. (4 pk)

**FOR USE WITH** All chain saws



REGULAR CHAPS (32"), DOLMAR

986-200-006



**SIZE** Regular (32 in.)

**FOR USE WITH** All chain saws



841008-A

38" CHAIN SAW CHAPS-LG



**SIZE** Long (38 in.)

**FOR USE WITH** All chain saws



REGULAR CHAPS (36") DOLMAR

986-200-007



**SIZE** Long (36 in.)

**FOR USE WITH** All chain saws



REGULAR CHAPS (40") DOLMAR

986-200-008



**SIZE** X-long (40 in.)

**FOR USE WITH** All chain saws



"COMBO" SAFETY HELMET, DOLMAR

986-200-002



**SIZE** Adjustable

**FOR USE WITH** All chain saws

CHAIN SAW



MAKITA PART #	DESCRIPTION	DOLMAR PART #
416311-7	5" CHAIN PROTECTOR	
452093-7	10" CHAIN PROTECTOR	165700-0
952-010-630	14" - 16" CHAIN PROTECTOR	952-010-130
952-010-640	18" CHAIN PROTECTOR	952-010-140
952-020-650	20" CHAIN PROTECTOR	952-020-150
952-020-660	24" CHAIN PROTECTOR	952-020-160
	32" CHAIN PROTECTOR	952-030-180



158476-6

4-1/2" GUIDE BAR WITH TIP GUARD



<b>BAR MOUNT</b>	Oregon #: N/A
<b>LENGTH (in.)</b>	4-1/2
<b>PITCH (in.)</b>	1/4
<b>GAUGE (in.)</b>	.050

<b>FITS MODELS:</b>	XCU01Z
---------------------	--------



165695-7

10" NARROW KERF GUIDE BAR

165700-0



<b>BAR MOUNT</b>	Oregon #: A318
<b>LENGTH (in.)</b>	10
<b>PITCH (in.)</b>	3/8
<b>GAUGE (in.)</b>	.050

<b>FITS MODELS:</b>	EY2650H25H
	ME-246.4



165245-8

12" NARROW KERF GUIDE BAR

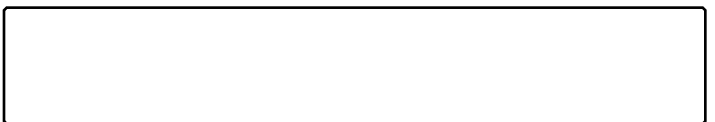

<b>BAR MOUNT</b>	Oregon #: A041
<b>LENGTH (in.)</b>	12
<b>PITCH (in.)</b>	3/8
<b>GAUGE (in.)</b>	.043

<b>FITS MODELS:</b>	HCU02ZX2	XCU04
	XCU02Z	
	HCU02C1	
	XCU03	



163150-3

12" GUIDE BAR WITH TIP GUARD

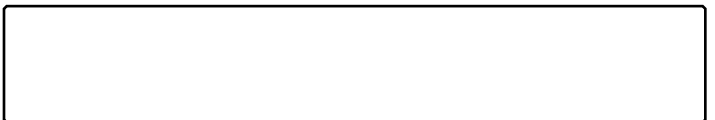

<b>BAR MOUNT</b>	Oregon #: N/A
<b>LENGTH (in.)</b>	12
<b>PITCH (in.)</b>	3/8
<b>GAUGE (in.)</b>	.050

<b>FITS MODELS:</b>	5102B
---------------------	-------

CHAIN SAW



165246-6

14" NARROW KERF GUIDE BAR



<b>BAR MOUNT</b>	Oregon #: A041
<b>LENGTH (in.)</b>	14
<b>PITCH (in.)</b>	3/8
<b>GAUGE (in.)</b>	.043

<b>FITS MODELS:</b>	XCU03
	XCU04



442-035-661

14" NARROW KERF GUIDE BAR

412-035-661

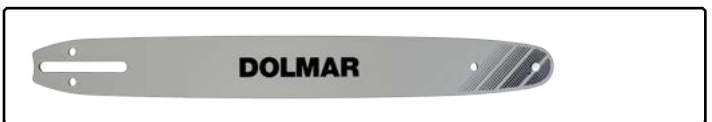

<b>BAR MOUNT</b>	Oregon #: A041
<b>LENGTH (in.)</b>	14
<b>PITCH (in.)</b>	3/8
<b>GAUGE (in.)</b>	.050

<b>FITS MODELS:</b>	XCU03	EA3500S	EA3601F
	XCU04	UC3551A	PS-32C
	EA3201S	U4051A	
	EA3200S	EA4300F	



443-038-631

15" MID RANGE GUIDE BAR

415-038-631



<b>BAR MOUNT</b>	Oregon #: K095
<b>LENGTH (in.)</b>	15
<b>PITCH (in.)</b>	.325
<b>GAUGE (in.)</b>	.058

<b>FITS MODELS:</b>	DCS5121	PS-5105A
	EA5000P	PS-6100
	EA6100P	EA5600F
	PS-510A	



442-040-661

16" MID RANGE GUIDE BAR

412-040-661



<b>BAR MOUNT</b>	Oregon #: A041
<b>LENGTH (in.)</b>	16
<b>PITCH (in.)</b>	3/8
<b>GAUGE (in.)</b>	.050

<b>FITS MODELS:</b>	EA3201S	EA3601F	PS-351
	UC3551A	PS-32C	XCU03
	U4051A	PS-421	
	EA4300F	PS-35C	

CHAIN SAW



### 16" REPLACEABLE TIP GUIDE BAR

431-040-014

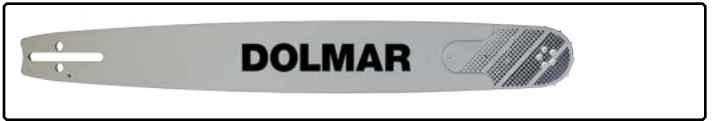

<b>BAR MOUNT</b>	Oregon #: K095
<b>LENGTH (in.)</b>	16
<b>PITCH (in.)</b>	3/8
<b>GAUGE (in.)</b>	.050

**FITS MODELS:**

DCS5121	PS-5105A
EA5000P	PS-6100
EA6100P	EA5600F
PS-510A	



### 16" MID RANGE GUIDE BAR

415-040-641



<b>BAR MOUNT</b>	Oregon #: K095
<b>LENGTH (in.)</b>	16
<b>PITCH (in.)</b>	.325
<b>GAUGE (in.)</b>	.050

**FITS MODELS:**

DCS5121	PS-5105
EA5000P	PS-6100
EA6100P	EA5600F
PS-510	



### 16" MID RANGE GUIDE BAR

415-040-631



<b>BAR MOUNT</b>	Oregon #: K095
<b>LENGTH (in.)</b>	16
<b>PITCH (in.)</b>	.325
<b>GAUGE (in.)</b>	.058

**FITS MODELS:**

DCS5121	PS-5105
EA5000P	PS-6100
EA6100P	EA5600F
PS-510	



443-045-661

### 18" MID RANGE GUIDE BAR

411-909-660



<b>BAR MOUNT</b>	Oregon #: K095
<b>LENGTH (in.)</b>	18
<b>PITCH (in.)</b>	3/8
<b>GAUGE (in.)</b>	.050

**FITS MODELS:**

DCS5121	PS-5105
EA5000P	PS-6100
EA6100P	EA5600F
PS-510	

CHAIN SAW





### 18" REPLACEABLE TIP GUIDE BAR

431-045-014



<b>BAR MOUNT</b>	Oregon #: K095
<b>LENGTH (in.)</b>	18
<b>PITCH (in.)</b>	3/8
<b>GAUGE (in.)</b>	.050

<b>FITS MODELS:</b>	DCS5121	PS-5105
	EA5000P	PS-6100
	EA6100P	EA5600F
	PS-510	



### 18" GUIDE BAR

415-045-641



<b>BAR MOUNT</b>	Oregon #: K095
<b>LENGTH (in.)</b>	18
<b>PITCH (in.)</b>	.325
<b>GAUGE (in.)</b>	.050

<b>FITS MODELS:</b>	DCS5121	PS-5105
	EA5000P	PS-6100
	EA6100P	EA5600F
	PS-510	



### 18" GUIDE BAR

415-045-631

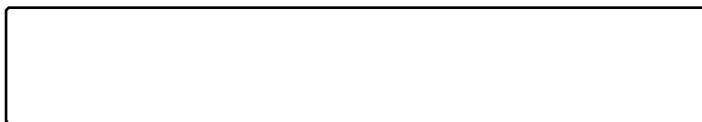

<b>BAR MOUNT</b>	Oregon #: K095
<b>LENGTH (in.)</b>	18
<b>PITCH (in.)</b>	.325
<b>GAUGE (in.)</b>	.058

<b>FITS MODELS:</b>	DCS5121	PS-5105
	EA5000P	PS-6100
	EA6100P	EA5600F
	PS-510	



443-053-661

### 20" GUIDE BAR

411-910-660



<b>BAR MOUNT</b>	Oregon #: K095
<b>LENGTH (in.)</b>	20
<b>PITCH (in.)</b>	3/8
<b>GAUGE (in.)</b>	.050

<b>FITS MODELS:</b>	DCS5121	PS-5105
	EA5000P	PS-6100
	EA6100P	EA5600F
	PS-510	

CHAIN SAW



445-050-665

20" GUIDE BAR

415-050-665



<b>BAR MOUNT</b>	Oregon #: D009
<b>LENGTH (in.)</b>	20
<b>PITCH (in.)</b>	3/8
<b>GAUGE (in.)</b>	.050

<b>FITS MODELS:</b>	DCS6421
	PS-6400
	PS-7310
	PS-7910



713200-A

20" REPLACEABLE TIP GUIDE BAR

431-050-014



<b>BAR MOUNT</b>	Oregon #: K095
<b>LENGTH (in.)</b>	20
<b>PITCH (in.)</b>	3/8
<b>GAUGE (in.)</b>	.050

<b>FITS MODELS:</b>	DCS5121	PS-5105
	EA5000P	PS-6100
	EA6100P	EA5600F
	PS-510	



20" GUIDE BAR

415-050-641

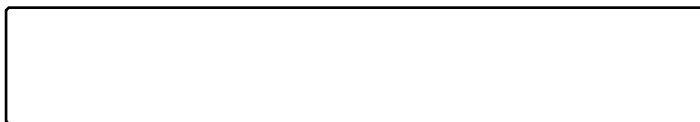

<b>BAR MOUNT</b>	Oregon #: K095
<b>LENGTH (in.)</b>	20
<b>PITCH (in.)</b>	.325
<b>GAUGE (in.)</b>	.050

<b>FITS MODELS:</b>	DCS5121	PS-5105
	EA5000P	PS-6100
	EA6100P	EA5600F
	PS-510	



20" REPLACEABLE TIP GUIDE BAR

431-050-013

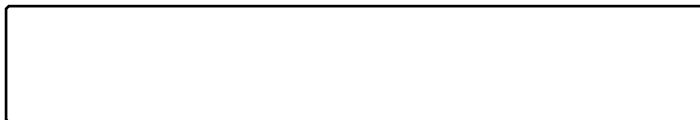

<b>BAR MOUNT</b>	Oregon #: D009
<b>LENGTH (in.)</b>	20
<b>PITCH (in.)</b>	3/8
<b>GAUGE (in.)</b>	.050

<b>FITS MODELS:</b>	DCS6421
	PS-6400
	PS-7310
	PS-7910

CHAIN SAW



### 24" GUIDE BAR

431-060-014



<b>BAR MOUNT</b>	Oregon #: K095
<b>LENGTH (in.)</b>	24
<b>PITCH (in.)</b>	3/8
<b>GAUGE (in.)</b>	.050

<b>FITS MODELS:</b>	EA6100P
	PS-6100



### 713205-A

### 24" REPLACEABLE TIP GUIDE BAR

431-060-013



<b>BAR MOUNT</b>	Oregon #: D009
<b>LENGTH (in.)</b>	24
<b>PITCH (in.)</b>	3/8
<b>GAUGE (in.)</b>	.050

<b>FITS MODELS:</b>	DCS6421
	PS-6400
	PS-7310
	PS-7910



### 713206-A

### 28" REPLACEABLE TIP GUIDE BAR

431-070-013



<b>BAR MOUNT</b>	Oregon #: D009
<b>LENGTH (in.)</b>	28
<b>PITCH (in.)</b>	3/8
<b>GAUGE (in.)</b>	.050

<b>FITS MODELS:</b>	DCS6421
	PS-6400
	PS-7310
	PS-7910



### 713207-A

### 32" REPLACEABLE TIP GUIDE BAR

431-080-013



<b>BAR MOUNT</b>	Oregon #: D009
<b>LENGTH (in.)</b>	32
<b>PITCH (in.)</b>	3/8
<b>GAUGE (in.)</b>	.050

<b>FITS MODELS:</b>	PS-7310
	PS-7910

CHAIN SAW

**791284-8****1/4" LOW PROFILE CHAIN, 4-1/2"****LENGTH (in.)**

4-1/2

**DRIVE LINKS**

42

**PITCH (in.)**

1/4

**FILE SIZE**

5/32

**GAUGE (in.)**

.050

**CHAIN TYPE**

25AP - low profile

**FOR USE WITH BAR #'S**

158476-6

**196142-7****3/8" LOW PROFILE CHAIN, 10"****LENGTH (in.)**

10

**DRIVE LINKS**

39

**PITCH (in.)**

3/8

**FILE SIZE**

.050

**GAUGE (in.)**

.050

**CHAIN TYPE**

91PX - low profile

**FOR USE WITH BAR #'S**

165695-7

**531-291-646****3/8" LOW PROFILE CHAIN, 12"****LENGTH (in.)**

12

**DRIVE LINKS**

46

**PITCH (in.)**

3/8

**FILE SIZE**

4.5 mm

**GAUGE (in.)**

.043

**CHAIN TYPE**

90SG - low vibration, low kickback

**FOR USE WITH BAR #'S**

165245-8

**196519-6****3/8" LOW PROFILE CHAIN, 12"****LENGTH (in.)**

12

**DRIVE LINKS**

45

**PITCH (in.)**

3/8

**FILE SIZE**

5/32

**GAUGE (in.)**

.050

**CHAIN TYPE**

91PX - low vibration, low kickback

**FOR USE WITH BAR #'S**

163150-3

**1967401-5****3/8" LOW PROFILE CHAIN, 14"****LENGTH (in.)**

14

**DRIVE LINKS**

52

**PITCH (in.)**

3/8

**FILE SIZE**

5/32

**GAUGE (in.)**

.043

**CHAIN TYPE**

90PX - low vibration, low kickback

**FOR USE WITH BAR #'S**

165246-6

**CHAIN SAW**



196207-5

3/8" LOW PROFILE CHAIN, 14"

511-492-052



LENGTH (in.)

14

DRIVE LINKS

52

PITCH (in.)

3/8

FILE SIZE

5/32

GAUGE (in.)

.050

CHAIN TYPE

91PX - low vibration, low kickback

FOR USE WITH BAR #'S

412-035-661  
165201-8



.325" LOW PROFILE CHAIN, 15"

523-085-064



LENGTH (in.)

15

DRIVE LINKS

64

PITCH (in.)

.325

FILE SIZE

4.5 mm

GAUGE (in.)

.058

CHAIN TYPE

34SL - Low Kickback

FOR USE WITH BAR #'S

443-038-631  
415-038-631



196208-3

3/8" LOW PROFILE CHAIN, 16"

511-492-056



LENGTH (in.)

16

DRIVE LINKS

56

PITCH (in.)

3/8

FILE SIZE

5/32

GAUGE (in.)

.050

CHAIN TYPE

91PX - low vibration, low kickback

FOR USE WITH BAR #'S

442-040-661  
412-040-661



523-100-060

3/8" CHAIN



LENGTH (in.)

16

DRIVE LINKS

60

PITCH (in.)

3/8

FILE SIZE

7/32

GAUGE (in.)

.050

CHAIN TYPE

72V - low kickback

FOR USE WITH BAR #'S



523-100-059

ROUND GROUND, 3/8" CHAIN, 16"



LENGTH (in.)

16

DRIVE LINKS

52

PITCH (in.)

3/8

FILE SIZE

7/32

GAUGE (in.)

.050

CHAIN TYPE

72LP - Chisel

FOR USE WITH BAR #'S

CHAIN SAW



### ROUND GROUND, .325" CHAIN

513-486-066



LENGTH (in.)

16

DRIVE LINKS

66

PITCH (in.)

.325

FILE SIZE

4.5 mm

GAUGE (in.)

.050

CHAIN TYPE

33SL - Low Kickback

FOR USE WITH BAR #'S

415-040-641



### ROUND GROUND, .325" CHAIN, 16"

523-085-066



LENGTH (in.)

16

DRIVE LINKS

66

PITCH (in.)

.325

FILE SIZE

4.5 mm

GAUGE (in.)

.058

CHAIN TYPE

34SL - Low Kickback

FOR USE WITH BAR #'S

415-040-631



523-102-064

### ROUND GROUND, 3/8" CHAIN, 18"



LENGTH (in.)

18

DRIVE LINKS

64

PITCH (in.)

3/8

FILE SIZE

7/32

GAUGE (in.)

.050

CHAIN TYPE

72V - low kickback

FOR USE WITH BAR #'S

443-045-661  
411-909-660



### ROUND GROUND, 3/8" CHAIN, 18"

523-100-068



LENGTH (in.)

18

DRIVE LINKS

68

PITCH (in.)

3/8

FILE SIZE

7/32

GAUGE (in.)

.050

CHAIN TYPE

72LP - Chisel

FOR USE WITH BAR #'S

431-045-014



528-086-672

### .325 LOW PROFILE CHAIN, 18"

513-486-072



LENGTH (in.)

18

DRIVE LINKS

72

PITCH (in.)

.325

FILE SIZE

4.5 mm

GAUGE (in.)

.050

CHAIN TYPE

33SL - Low Kickback

FOR USE WITH BAR #'S

415-045-641

CHAIN SAW



### ROUND GROUND, .325" CHAIN, 18"

523-085-072



LENGTH (in.)

18

DRIVE LINKS

72

PITCH (in.)

.325

FILE SIZE

4.5 mm

GAUGE (in.)

.058

CHAIN TYPE

34SL - Low Kickback

FOR USE WITH BAR #'S

415-045-631



523-102-072A

### ROUND GROUND, 3/8" CHAIN, 20"



LENGTH (in.)

20

DRIVE LINKS

72

PITCH (in.)

3/8

FILE SIZE

7/32

GAUGE (in.)

.050

CHAIN TYPE

72V - low kickback

FOR USE WITH BAR #'S

443-053-661

431-050-014

445-050-665

411-910-660

713200-A

415-050-665



713100-A

### ROUND GROUND, 3/8" CHAIN, 20"



LENGTH (in.)

20

DRIVE LINKS

69

PITCH (in.)

3/8

FILE SIZE

7/32

GAUGE (in.)

.050

CHAIN TYPE

72V - low kickback

FOR USE WITH BAR #'S



### ROUND GROUND, 3/8" CHAIN, 20"

523-100-072



LENGTH (in.)

20

DRIVE LINKS

72

PITCH (in.)

3/8

FILE SIZE

7/32

GAUGE (in.)

.050

CHAIN TYPE

72LP - Chisel

FOR USE WITH BAR #'S

443-053-661

431-050-014

445-050-665

411-910-660

713200-A

415-050-665



### ROUND GROUND, .325" CHAIN, 20"

513-486-078



LENGTH (in.)

20

DRIVE LINKS

78

PITCH (in.)

.325

FILE SIZE

4.5 mm

GAUGE (in.)

.050

CHAIN TYPE

33SL - Low Kickback

FOR USE WITH BAR #'S

415-050-641

CHAIN SAW

**713105-A****ROUND GROUND, 3/8" CHAIN, 24"****LENGTH (in.)**

24

**DRIVE LINKS**

84

**PITCH (in.)**

3/8

**FILE SIZE**

7/32

**GAUGE (in.)**

.050

**CHAIN TYPE**

72LP - Chisel

**FOR USE WITH BAR #'S**713201-A 431-060-013  
431-060-014 713205-A**713106-A****ROUND GROUND, 3/8" CHAIN, 28"****LENGTH (in.)**

28

**DRIVE LINKS**

92

**PITCH (in.)**

3/8

**FILE SIZE**

7/32

**GAUGE (in.)**

.050

**CHAIN TYPE**

72LP - Chisel

**FOR USE WITH BAR #'S**713202-A 713206-A  
431-070-013**713107-A****ROUND GROUND, 3/8" CHAIN, 32"****523-100-105****LENGTH (in.)**

32

**DRIVE LINKS**

105

**PITCH (in.)**

3/8

**FILE SIZE**

7/32

**GAUGE (in.)**

.050

**CHAIN TYPE**

72LP - Chisel

**FOR USE WITH BAR #'S**713207-A  
431-080-013





### POWER CUTTER METAL CASE

988-959-402

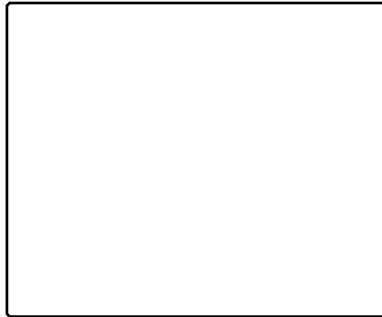

#### FOR USE WITH

EK6101	PC-7414
EK7301	
PC-6114	
PC-7412	



988-394-610

### PRESSURIZED WATER TANK

988-394-110



#### FOR USE WITH

EK8100	PC-6114
EK7651H	PC-7412
EK6101	PC-7414
EK7301	



010-114-080

### ANGULAR UNION ASSY



#### FOR USE WITH

EK8100	PC-8216
EK7301	
PC-7412	
PC-7414	

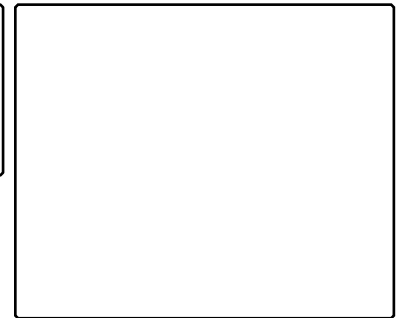

DT2010

### POWER CUTTER DOLLY WITH WATER TANK

PT2010



#### FOR USE WITH

EK7301	PC-8216
EK8100	
PC-7412	
PC-7414	



POWER CUTTER



**FOR USE WITH**

EK7651H

